

SmartAssembly™ for Creo (Pro/Engineer)

Radical productivity improvement for your Creo implementation

What is SmartAssembly?

SmartAssembly is a process capture tool that allows users to focus on the design process, instead of being bogged down with the repetitive tasks that are present in every design. It is a development engine that allows users to create UDF's, assemble existing parts or sub-assemblies, and configure new parts or sub-assemblies with associated drawings from existing company templates. Users develop programs in a simple easy to use language. Most programs are only a few paragraphs long.

Key Features

- Automatic creation & configuration of new parts and sub-assemblies
- Automatic assembly of newly created or existing parts or sub-assemblies
- Creation of part level features
- Support for part family tables and assembly level family tables
- Support for BMX features
- Dimensional information provided thru user input or automatically from the program
- Automatic relations from analysis features when assembling a component
- All components and features created still have full redefine or edit definition capability
- When a component is removed, the associated UDF's and relations are also removed
- Export parameters or references from UDF's for use elsewhere in the program
- Display measurement information and pass them for use in UDF's or in components
- Rich programming flexibility – loops, conditional statements, variables, etc.
- Manufacturing and Drawing Automation Support
- Works with Pro/Intralink and PDMLink

How It Works

- Define required automation rules using UDF's, standard components and assemblies, SmartAssembly programming, and the required GUI
- Work either in part mode to add features or at the assembly level to add features or components
- Define project templates and re-use the data –automatically copy, rename a top-level assembly and all drawings, parts, sub-assemblies, even manufacturing files!
- Use the SmartAssembly GUI to speed up all design and manufacturing tasks

Key Benefits

- Standardization of assemblies and parts
- New users can be productive in a fraction of the time
- Productivity improvements of 50-80% are commonly recognized
- Advanced users create designs faster allowing them to focus on the design process
- Re-use company standard libraries – create automation programs from existing components in hours
- UDF organization – eliminates common UDF problems such as UDF naming, gph file location, or required references

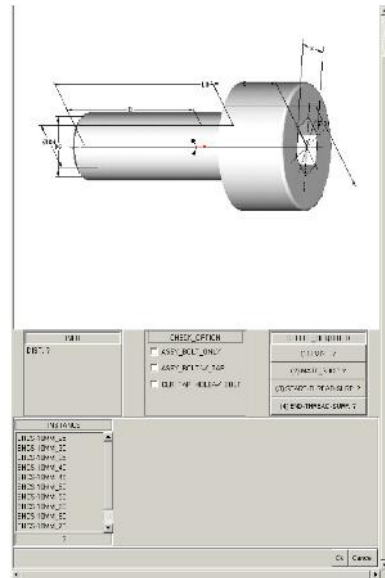

User-defined GUI prompts for all required options, dimensions and references.

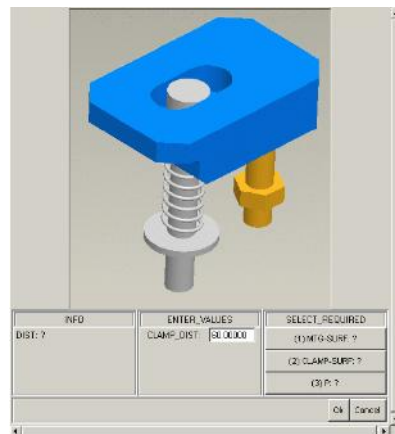

User-defined graphics are incorporated in the automation GUI

For more info contact SIGMAXIM, Inc. at: info@sigmaxim.com or toll free at 877-SIGMAXIM, or visit us on the web at www.sigmaxim.com.